

# BFM

## Balanced flue commercial water heater

**BFM – 30/50/80/100/120**



Wide range of balanced fanned flue room-sealed water heaters for installation in almost any location • Improved efficiency • Removable control column for convenient servicing • Control, high limit and energy cut-off thermostat triple protection ensures safe operation • Frost-protection thermostat • Stainless-steel burner for natural or LP gas • Two access covers for comprehensive waterside tank maintenance • Voltage-free contact for general fault indication • Steel pallet base for convenient transport and installation • Optional ancillaries: Unvented kits • De-stratification pump kit • Powered anode

# Technical specifications

		BFM 30	BFM 50	BFM 80	BFM 100	BFM 120
<b>Gas data natural gas 2H (G20)</b>						
Input*	kW	32.2	52.2	83.3	113.3	127.7
Output	kW	26.4	42.3	67.5	90.8	102.4
Inlet pressure	mbar	20	20	20	20	20
Gas consumption**	m <sup>3</sup> /h	3.1	5.0	7.9	10.8	12.2
Flue gas discharge	kg/h	74.2	105.7	191.9	232.5	265.8
<b>Gas data butane 3+ (G30)</b>						
Input*	kW	31.4	49.9	81.3	110.5	n/a
Output	kW	26.4	41.4	67.5	90.8	n/a
Inlet pressure	mbar	30	30	30	30	n/a
Gas consumption**	kg/h	2.3	3.6	5.9	8.0	n/a
Flue gas discharge	kg/h	75.6	105.6	200.9	226.1	n/a
<b>Gas data propane 3+ (G31)</b>						
Input*	kW	30.4	47.8	77.2	110.9	125.0
Output	kW	25.5	39.6	63.9	90.8	102.4
Inlet pressure	mbar	37	37	37	37	37
Gas consumption**	kg/h	2.2	3.4	5.5	7.9	8.9
Flue gas discharge	kg/h	71.4	105.1	194.3	232.0	264.7
<b>General</b>						
Efficiency (gross)	%	82	81	81	80	80
Weight empty	kg	230	245	295	320	320
Maximum weight	kg	539	543	548	573	573
Storage capacity	l	309	298	253	253	253
Maximum working pressure	(bar) kPa			(8) 800		
Max. temperature setting	°C	73	73	73	73	73
<b>Draw-off capacity</b>						
T <sub>cold</sub> = 10°C / T <sub>set</sub> = T <sub>max</sub>						
30 min. ΔT=44°C	l	586	713	883	1088	1190
60 min. ΔT=44°C	l	844	1127	1543	1975	2190
90 min. ΔT=44°C	l	1102	1540	2203	2863	3191
120 min. ΔT=44°C	l	1360	1954	2862	3750	4191
Continuous ΔT=44°C	l/h	516	827	1319	1774	2000
Heating-up time ΔT=44°C	min.	36	22	12	9	8
30 min. ΔT=50°C	l	516	628	777	958	1047
60 min. ΔT=50°C	l	743	992	1358	1738	1927
90 min. ΔT=50°C	l	970	1355	1938	2519	2808
120 min. ΔT=50°C	l	1197	1719	2519	3300	3688
Continuous ΔT=50°C	l/h	454	728	1161	1561	1760
Heating-up time ΔT=50°C	min.	41	25	13	10	9
30 min. ΔT=55°C	l	469	571	707	871	952
60 min. ΔT=55°C	l	675	901	1235	1580	1752
90 min. ΔT=55°C	l	881	1232	1762	2290	2552
120 min. ΔT=55°C	l	1088	1563	2290	3000	3353
Continuous ΔT=55°C	l/h	413	661	1055	1419	1600
Heating-up time ΔT=55°C	min.	45	27	14	11	9
<b>Electrical data</b>						
Power consumption	W	100	100	100	275	300
Power supply	VAC/Hz	230 (-15/+10%) / 50 (± 1Hz)				
<b>Shipping data</b>						
Weight incl. packaging	kg	260	275	325	350	350
Width packaging	mm	800	800	800	800	800
Height packaging	mm	2080	2080	2080	2080	2080
Depth packaging (excl. anode)	mm	1040	1040	1040	1040	1040

\* Gas data on gross value

\*\* Gas consumption at 15°C and 1013.25 mbar

# Dimensions

BFM 30-80

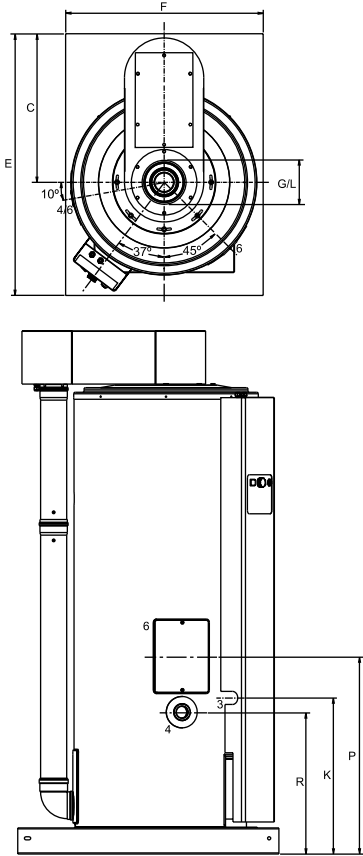

	BFM 30	BFM 50	BFM 80	BFM 100	BFM 120
A	2000	2000	2020	2020	2020
B	1800	1800	1820	1820	1820
C	580	580	580	580	580
D	710	710	710	710	710
E	1000	1000	1000	1000	1000
F	755	755	755	755	755
G	80	100	130	130	130
Hy	-	-	-	235	235
K	600	600	600	600	760
L	125	150	200	130	130
M	600	600	590	590	590
N	1640	1640	1655	1655	1655
P	770	770	760	760	760
R	550	550	540	540	540
S	1600	1600	1600	1600	1600
1	Cold water (external)			R1½	
2	Hot water (internal)			Rp1½	
3	Gas control (internal)			Rp¾ (BFM120 = Rp1)	
4	Tank drain valve (internal)			Rp1½	
5	T&P valve (internal)			1-11.5 NPT (BFM 30-50) Rp1½ (BFM 80-120)	
6	Cleaning and inspection opening			Ø100	

Dimensions in mm.

BFM 100-120

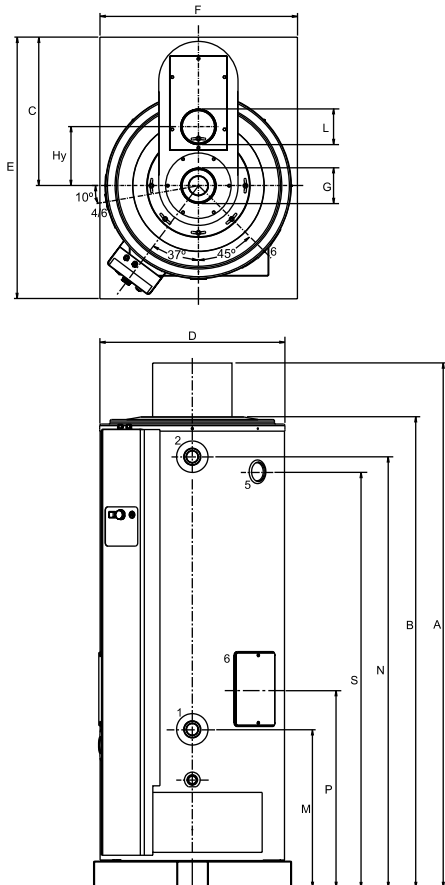

# Installation diagrams

Vented

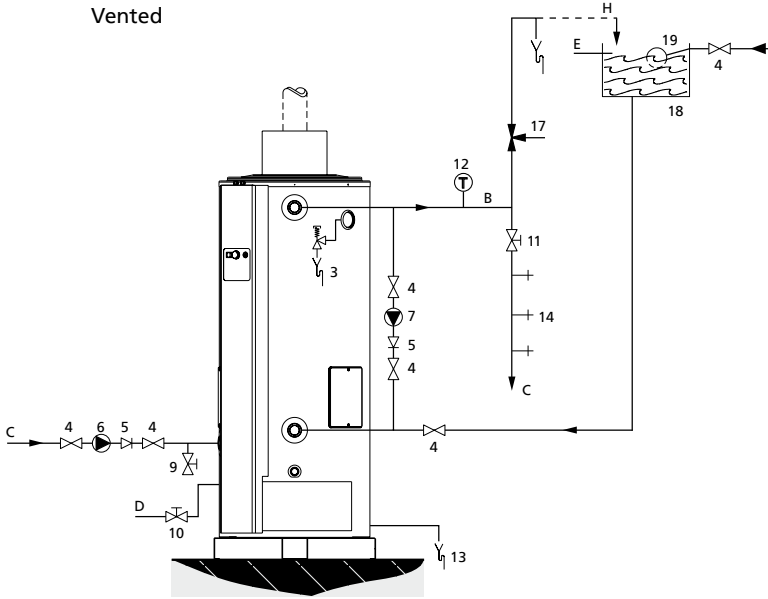

- 1 Pressure reducing valve
- 3 T&P valve
- 4 Stop valve
- 5 Non-return valve
- 6 Circulation pump
- 7 Destratification pump
- 9 Drain valve
- 10 Gas valve
- 11 Service valve
- 12 Temperature meter
- 13 Condense drain
- 14 Hot water tap
- 15 Expansion valve
- 16 Expansion vessel
- 17 Three way valve
- 18 Water cistern
- 19 Float valve

- A Cold water supply
- B Hot water outlet
- C Return circulation
- D Gas supply
- E Overflow pipe
- H Overflow protection

A.O. Smith unvented system kits utilise combination valves.

Further installation and connection details can be found in the Installation & Commissioning Manual.

Unvented

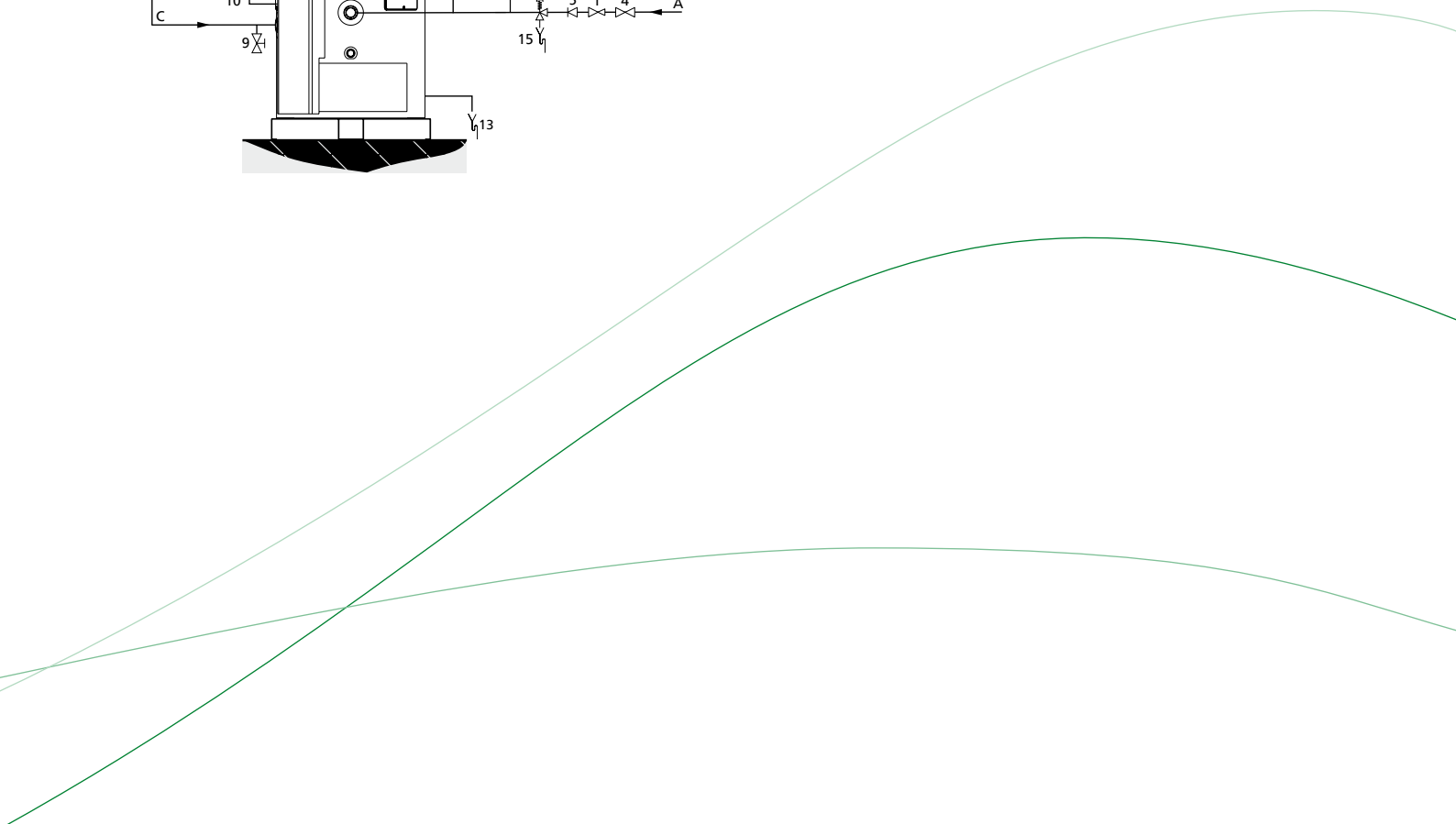
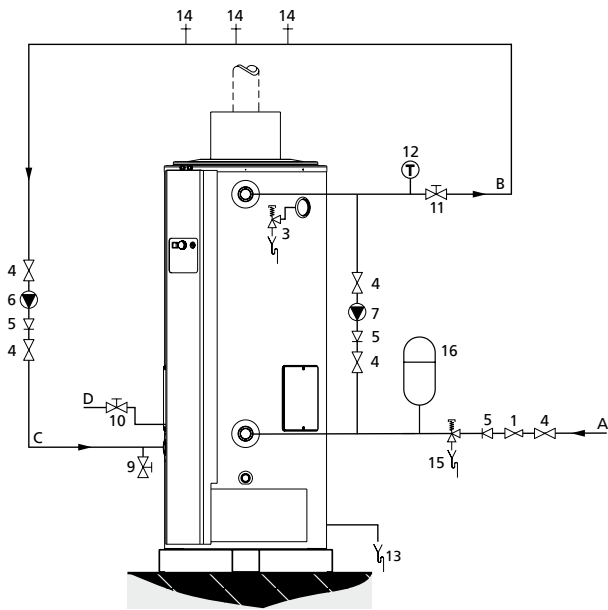

## Features and options

- Wide range of balanced fanned flue room-sealed water heaters for installation in almost any location
- Improved efficiency
- Removable control column for convenient servicing
- Control, high limit and energy cut-off thermostat triple protection ensures safe operation
- Frost-protection thermostat
- Stainless-steel burner for natural or LP gas
- Two access covers for comprehensive waterside tank maintenance
- Voltage-free contact for general fault indication
- Steel pallet base for convenient transport and installation
- Optional ancillaries: Unvented kits
- Destratification pump kit
- Powered anode

# Installation options

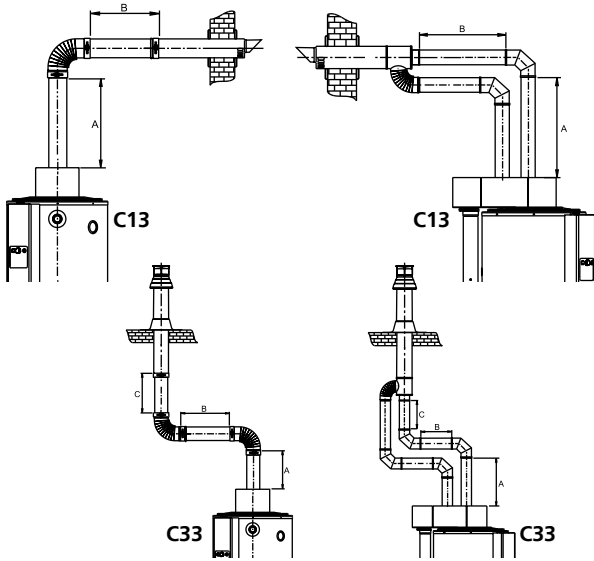

A BFM water heater should be installed according category C13 or C33.

	BFM 30	BFM 50	BFM 80	BFM 100	BFM 120
Concentric	x	x	x	-	-
Parallel	-	-	-	x	x
Diameter (mm)	80/125	100/150	130/200	2 x 130	2 x 130
Max. length (m)	7	7	7	7	7
Max. 45/90° bends a pipe	2	2	2	2	2

**Concentric flues**

It is **not** permitted to use more than the specified number of bends, even when the duct is shorter than the maximum length. A 45° bend is equivalent to a 90° bend.

**Parallel flues**

The parallel flue of a BFM 100 or 120 unit should always be connected to the wall or roof penetration using the standard transition piece (0306801). The two ducts shall **not** terminate in different pressure zones.

Note: horizontal flue runs must be installed with a fall of at least 5 mm per metre.

Further information on the flue gas discharge materials can be found in the Installation & Commissioning Manual.

# Minimum space requirements

BFM 30-80

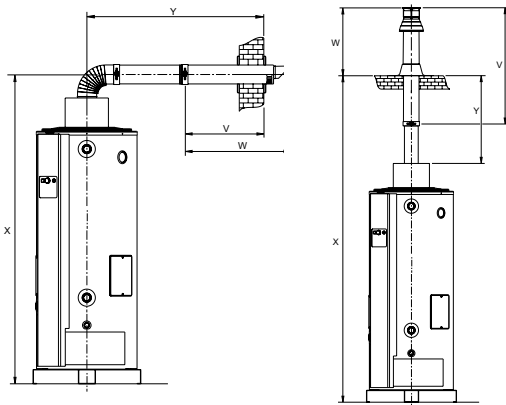

BFM 100-120

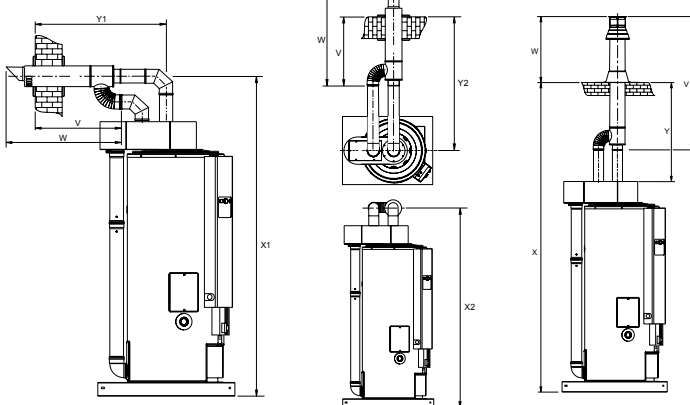

	BFM 30 Ø80/125	BFM 50 Ø100/150	BFM 80 Ø130/200	BFM 100 2 x Ø130	BFM 120 2 x Ø130
<b>Minimal space for wall duct (mm)</b>					
V	550	550	550	550	640
W	725	790	940	790	940
X	2115	2165	2190		
X *	1665	1715	1740		
Y	1195	1215	1310		
Y *	745	765	860		
X1				2480	2480
Y1				955	955
X2				2140	2140
Y2				870	870
<b>Minimal space for roof duct (mm)</b>					
V	1230	1310	1610	2560	2560
W	605	645	1000	1000	1000
X	3575	3615	3580	3580	3580
X **	2625	2665	2630	2630	2630
Y	1575	1615	1560	1560	1560
Y **	625	665	610	610	610

\* Distance without concentric pipe between bend and wall duct.  
 \*\* Distance without concentric pipe between appliance and roof duct.

Data subject to change UK/0810/BFM/02  
 Terms and conditions apply, please refer to our website.